



Capacity from 500 kg to 5000 kg



- SPECIAL STEEL
- COMBINED ERROR $\leq \pm 0.02\%$ (0.017% C4; 0.014% C5)
- PROTECTION CLASS IP67

MOUNTING KITS



CAPACITY	kg	ACCURACY CLASS			IECEx	Ex	EAC	NTEP	NET WEIGHT OF LOAD CELL (kg)	CODE
		C3	C4	C5						
500		•	•	•	•	•	•	0.8	FTKL500	
1000		•	•	•	•	•	•	0.8	FTKL1000	
1500		•	•	•	•	•	•	0.9	FTKL1500	
2000		•	•	•	•	•	•	0.9	FTKL2000	
3000		•	•	•	•	•	•	1.7	FTKL3000	
5000		•	•	•	•	•	•	1.7	FTKL5000	

ON REQUEST

CERTIFICATIONS

OIML R60 C3

CERTIFICATIONS ON REQUEST

ATEX II 1GD (zone 0-1-2-20-21-22)

IECEx (zone 0-1-2-20-21-22)

OIML R60 C4/C5

Complies with the Eurasian Custom Union regulations (Russia, Belarus, Kazakhstan)

NTEP - compliant to the metrological standards of United States and Canada (capacity from 50 to 500 kg)

DIMENSIONS (mm)

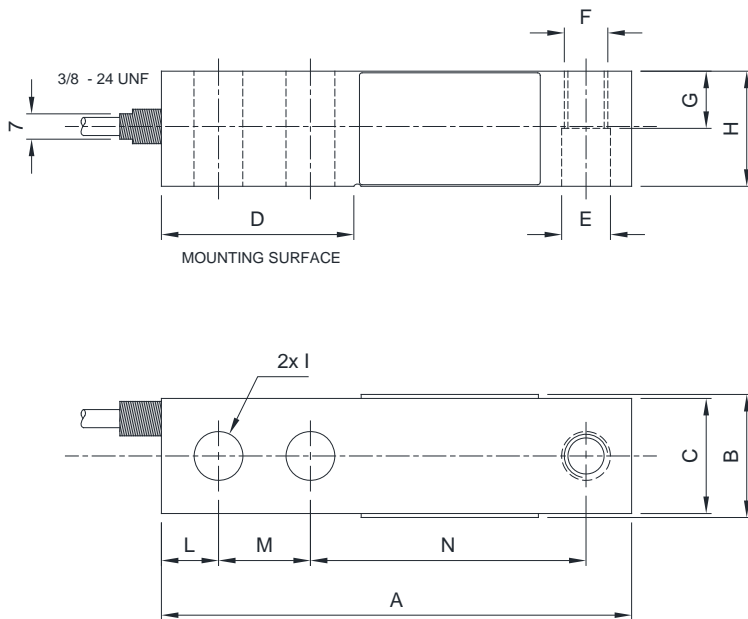

	500 kg	1000 - 1500 2000 kg	3000 - 5000 kg
A	130	130	171.5
B	-	32.8	39.1
C	31.8	31.8	38.1
D	53.2	53.2	76.2
E	Ø13.5	Ø13.5	Ø19.8
F	M12x1.75	M12x1.75	M18x1.5
G	16	16	19.3
H	31.8	31.8	38.1
I	Ø13.5	Ø13.5	Ø19.8
L	15.8	15.8	19.1
M	25.4	25.4	38.1
N	76.2	76.2	95.3

TECHNICAL FEATURES

Material	Special steel			
	C3 • 3000	C4 • 4000	C5 • 5000	
OIML R60 Accuracy class • Verification intervals	500 - 1000 - 1500 kg 2000 - 3000 - 5000 kg		500 - 1000 kg 1500 - 2000 kg	3000 - 5000 kg
Nominal load (E max)	E max / 10000		E max / 15000	E max / 20000
Minimum verification interval (V min)	E max / 10000		E max / 15000	E max / 18000
Combined error	≤ ±0.02%	≤ ±0.017%	≤ ±0.014%	
Protection class	IP67			
Rated output	3 mV/V ±0.1%	Input resistance	350 Ω ±3.5	
Temperature effect on zero	0.0018% °C	Output resistance	350 Ω ±3.5	
Temperature effect on span	0.0014% °C	Zero balance	≤ ±1%	
Compensated temperature range	-10 °C / +40 °C	Insulation resistance	≥ 5000 MΩ	
Operating temperature range	-35 °C / +65 °C	Safe overload (% of full scale)	150%	
Creep at nominal load in 30 minutes	0.02%	Ultimate overload (% of full scale)	300%	
Max supply voltage without damage	18 V	Deflection at nominal load	0.4 mm	

ELECTRICAL CONNECTIONS

Cable length	4 m (500-2000 kg); 6 m (3000-5000 kg)
Cable diameter	5 mm
Cores	4/6 x 0.20 mm ²

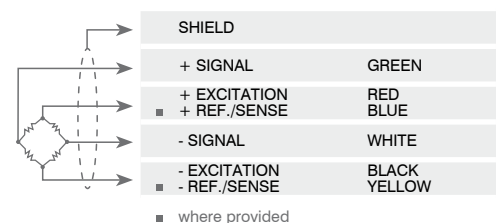

The Company reserves the right to make changes to the technical data, drawings and images without notice.