



Manufactured according to OIML R60 standards

Capacity from 200 kg to 2500 kg



- 17-4 PH STAINLESS STEEL
- COMBINED ERROR  $\leq \pm 0.5\%$
- PROTECTION CLASS IP67

CAPACITY	kg	IECEx	Ex	EAC	NET WEIGHT OF LOAD CELL (kg)	CODE
200		•	•	•	0.11	CK200
500		•	•	•	0.08	CK500
1000		•	•	•	0.17	CK1000
2500		•	•	•	0.17	CK2500

ARICHIESTA

### CERTIFICATIONS

#### CERTIFICATIONS ON REQUEST



ATEX II 1GD (zone 0-1-2-20-21-22)



IECEx (zone 0-1-2-20-21-22)



Complies with the Eurasian Custom Union regulations (Russia, Belarus, Kazakhstan)

### DIMENSIONS (mm)

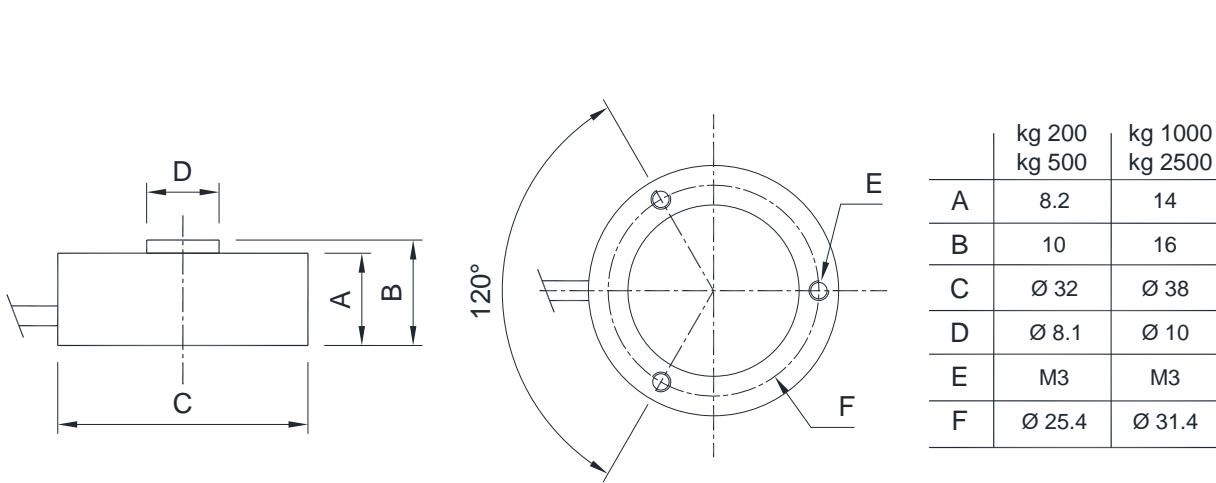

### TECHNICAL FEATURES

Material	17-4 PH stainless steel		
Nominal load (E max)	200 - 500 - 1000 - 2500 kg		
Combined error	≤ ±0.5%		
Protection class	IP67		
Rated output	1 mV/V ±15%	Input resistance	400 Ω ±100
Temperature effect on zero	0.005% °C	Output resistance	350 Ω ±5
Temperature effect on span	0.005% °C	Zero balance	±1%
Compensated temperature range	-10 °C / +50 °C	Insulation resistance	>5000 MΩ
Operating temperature range	-20 °C / +70 °C	Safe overload (% of full scale)	120%
Creep at nominal load in 30 minutes	0.3%	Ultimate overload (% of full scale)	200%
Max supply voltage without damage	15 V	Deflection at nominal load	0.3 mm

### ELECTRICAL CONNECTIONS

Cable length	5 m
Cable diameter	3 mm
Cores	4/6 x 0.25 mm <sup>2</sup>

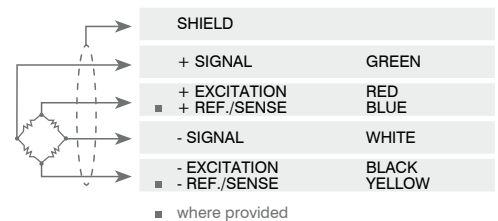

The Company reserves the right to make changes to the technical data, drawings and images without notice.